

200# WOG STAINLESS STEEL SWING CHECK VALVE

FIG. VT-C



Marking: MSS SP-25
 Ends: MSS SP-110, ANSI B2.1
 Size range: ¼" to 2"
 Pressure ¼" to 2": 200 psi (WOG)
 Max. Temperature: 350 °F
 Integral Seat

Materials:

No.	Part Name	Specification
1	Body	ASTM A351-CF8M
2	Cap	ASTM A351-CF8M
3	Disc	ANSI 316
4	Hinge Pin	ANSI 316
5	Gasket	PTFE
6	Plug	ANSI 316

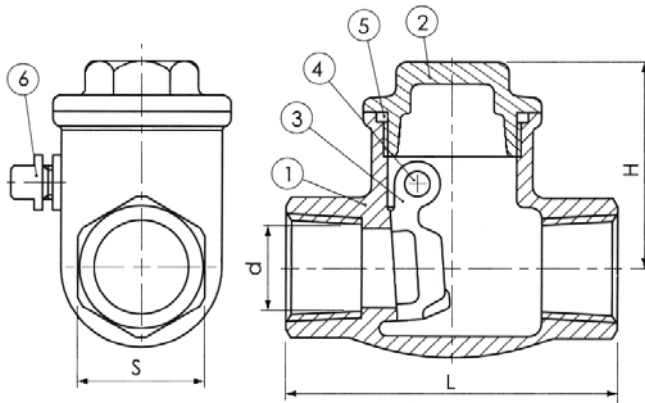

Dimensions:

Size		d		L		S		H	
in	mm	in	mm	in	mm	in	mm	in	mm
¼"	8	0.43	11	2.56	65	1.06	27	1.77	45
⅜"	10	0.47	12	2.56	65	1.06	27	1.77	45
½"	15	0.59	15	2.56	65	1.06	27	1.77	45
¾"	20	0.79	20	3.15	80	1.34	34	2.17	55
1"	25	1.00	25.4	3.54	90	1.57	40	2.28	58
1¼"	32	1.25	25.4	4.13	105	1.97	50	2.44	62
1½"	40	1.50	38	4.72	120	2.24	57	2.95	75
2"	50	1.97	50	5.51	140	2.76	70	3.07	78