

1000 WOG - 2 PIECE FULL PORT DIRECT MOUNT BALL VALVE

FIG. V-2MH

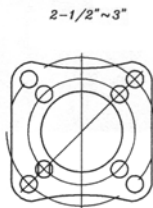
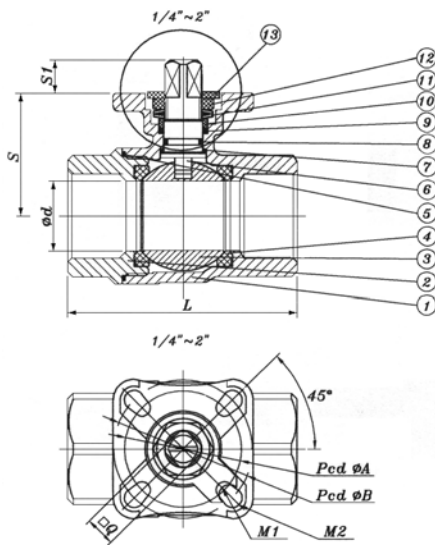
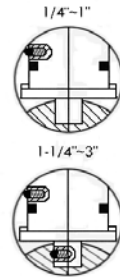

Valves - Threaded: ANSI B16.34
 Ends: MSS SP-110, ASME B16.25, MSS SP-72
 Marking: MSS SP-25
 Testing: API 598
 Threaded ends: ANSI B2.1
 Size range: 1/4" to 3"
 Pressure 1/4" to 3": 1000 psi (WOG)
 Blow-out proof stem

Materials:

No.	Part Name	Specification
1	Body	ASTM A351-CF8M
2	End Cap	ASTM A351-CF8M
3	Ball	ASTM A351-CF8M/316
4	Seat	15% R-PTFE
5	Joint Gasket	PTFE
6	Stem	ANSI 316
7	Thrust Washer	PTFE
8	O-Ring	Viton
9	Stem Packing	PTFE
10	Stem Ring	ANSI 304
11	Belleville Washer	ANSI 304
12	Stem Nut	ANSI 304
13	Stopper	ANSI 304

Options:

- P: equipped with Pneumatic actuator
- L: Locking Device

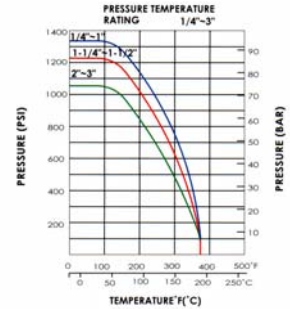

Dimensions:

Size		i d		L		S	S1	ISO 5211								Torque	Weights	
in	mm	in	mm	in	mm	mm	mm	Pcd	i A	i Q	Pcd	i B	M1	M2	in/lbs	lb	kg	
1/4"	8	.46	11.6	1.95	49.6	36	10	F03	36	9	-	-	6.0	-	39	.68	0.31	
3/8"	10	.5	12.7	1.95	49.6	36	10	F03	36	9	-	-	6.0	-	39	.68	.031	
1/2"	15	.59	15	2.17	55	38	10	F04	42	9	-	-	6.0	-	48	.75	0.34	
3/4"	20	.79	20	2.97	75.5	41.7	12	F04	42	11	F05	50	R3.0	R3.5	78	1.36	0.62	
1"	25	.99	25.4	3.25	82.5	44.4	12	F04	42	11	F05	50	R3.0	R3.5	96	1.72	0.78	
1 1/4"	32	1.26	32	3.57	90.8	54	16.5	F05	50	14	F07	70	R3.5	R4.5	135	2.97	1.35	
1 1/2"	40	1.5	38	4.06	103	59.5	16.5	F05	50	14	F07	70	R3.5	R4.5	191	4.20	1.91	
2"	50	2	50.8	4.72	120	67	16.5	F05	50	14	F07	70	R3.5	R4.5	286	6.16	2.8	
2 1/2"	65	2.6	65	6.10	155	101.5	24.5	F07	70	17	F10	102	R9.0	R11	347	15.36	6.98	
3"	80	3.15	80	7.17	182	112.5	24.5	F07	70	17	F10	102	R9.0	R11	573	22.66	10.3	