



1000 WOG - 2 PIECE FULL PORT STAINLESS STEEL BALL VALVE

FIG. V-2E



Ends: MSS SP-110, ASME B16.25, MSS SP-72
 Marking: MSS SP-25
 Threaded ends: ANSI B1.20.1
 Size range: 1/4" to 3"
 Pressure 1/4" to 3": 1000 psi (WOG)

Materials:

No.	Part Name	Specification
1	Body	ASTM A351-CF8M
2	End Cap	ASTM A351-CF8M
3	Ball	ASTM A351-CF8M
4	Stem	ASTM A276-316
5	Gland Nut	AISI 304
6	Seats	15% RPTFE
7	Body Seal	PTFE
8	Stem Packing	PTFE
9	Thrust Washer	PTFE
10	Spring Washer	AISI 304
11	Handle Nut	AISI 304
12	Handle	AISI 304
13	Handle Sleeve	Plastic
14	Lock Device	AISI 304

Options:

- M: Tapped Mounting pad
- P: equipped with Pneumatic actuator
- U: UNC or UNF threads for mounting pad
- L: Locking Device

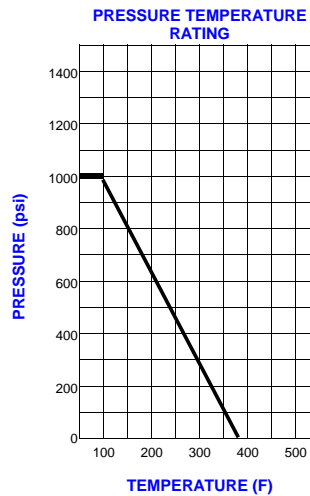
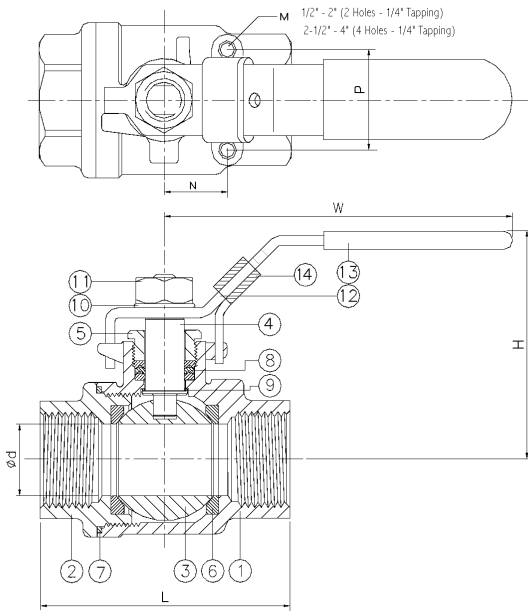

Dimensions:

Size		i d		L		H		N		P		W		M	Weights	
in	mm	in	mm	in	mm	in	mm	in	mm	in	mm	in	mm	(Option)	lb	kg
1/4"	8	0.46	11.6	1.75	44.5	2.01	51	.49	12.5	.98	25	3.74	95	M5	.46	.21
3/8"	10	0.50	12.7	1.75	44.5	2.01	51	.49	12.5	.98	25	3.74	95	M5	.48	.22
1/2"	15	0.59	15	2.24	57	2.09	53	.49	12.5	.98	25	3.74	95	M5	.50	.228
3/4"	20	0.79	20	2.56	65	2.34	59.5	.83	21	.94	24	4.33	110	M5	.93	.442
1"	25	0.96	25	2.99	76	2.87	73	.89	22.5	1.32	33.5	5.31	135	M5	1.55	.706
1 1/4"	32	1.26	32	3.44	87.5	3.11	79	.93	23.5	1.50	38.1	5.31	135	M6	2.33	1.06
1 1/2"	40	1.50	38	4.02	102	3.56	90.5	.93	23.5	1.50	38.1	6.50	165	M6	3.70	1.68
2"	50	1.97	50	4.84	123	3.88	98.5	.93	23.5	1.50	38.1	6.50	165	M6	5.96	2.71
2 1/2"	65	2.56	65	6.14	156	5.14	130.5	1.38	35	2.20	56	8.46	215	M6	11.55	5.25
3"	80	3.15	80	7.24	184	5.61	142.5	1.38	35	2.20	56	8.46	215	M6	18.92	8.60