

Class 150

Cast Carbon Steel Check Valve

Bolted cover, Swing type disc.



150 SCO

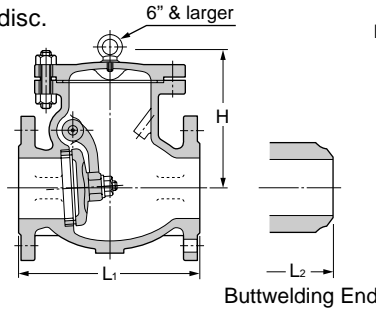

Note : Refer to Page 2 & 3 for standard seat material and construction.

Fig	End Connections
150 SCO	RF-flanged with smooth finish on gasket surface.
W150 SCO	Butt-welding ends.

Standard materials of parts

Parts	Materials
Body	ASTM A216 Gr.WCB
Cover	A105/ASTM A216 Gr.WCB
Disc	ASTM A182 Gr.F6a (1 1/2" - 6") ASTM A216 Gr.WCB + 13Cr (8" & larger)
Disc nut	ASTM A194 Gr.8
Body seat ring	ASTM A182 Gr.F6a
Cover bolt / nut	ASTM A193 Gr.B7/A194 Gr.2H
Arm	ASTM A105 (1 1/2" - 14") ASTM A216 Gr.WCB (16" & larger)
Gasket	See Page 7.
Plug	ASTM A576 Gr.1045

Dimensions

Valve Size	in	1 1/2	2	2 1/2	3	4	5	6	8	10	12	14	16	18	20	22	24	26	28	30
	mm	40	50	65	80	100	125	150	200	250	300	350	400	450	500	550	600	650	700	750
L ₁	in	6.50	8.00	8.50	9.50	11.50	13.00	14.00	19.50	24.50	27.50	31.00	34.00	38.50	38.50	42.00	51.00	51.00	57.00	60.00
	mm	165	203	216	241	292	330	356	495	622	698	787	864	978	978	1067	1295	1295	1448	1524
L ₂	in	6.50	8.00	8.50	9.50	11.50	13.00	14.00	19.50	24.50	27.50	31.00	34.00	38.50	38.50	42.00	51.00	51.00	57.00	60.00
	mm	165	203	216	241	292	330	356	495	622	698	787	864	978	978	1067	1295	1295	1448	1524
H	in	5.3	6.0	6.7	7.1	7.9	9.25	9.8	11.6	13.2	14.5	16.3	18.1	20.1	21.7	23.0	24.8	26.8	28.2	29.9
	mm	135	152	170	180	200	235	250	295	334	368	415	460	510	550	585	630	680	716	760

Class 300

Cast Carbon Steel Check Valve

Bolted cover, Swing type disc.



300SCO

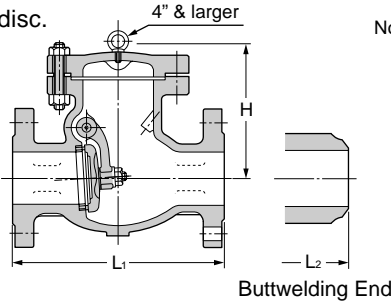

Note : Refer to Page 2 & 3 for standard seat material and construction.

Fig	End Connections
300 SCO	RF-flanged with smooth finish on gasket surface.
W300 SCO	Butt-welding ends.

Standard materials of parts

Parts	Materials
Body	ASTM A216 Gr.WCB
Cover	A105/ASTM A216 Gr.WCB
Disc	ASTM A182 Gr.F6a (1 1/2" - 6") ASTM A216 Gr.WCB + 13Cr (8" & larger)
Disc nut	ASTM A194 Gr.8
Body seat ring	ASTM A182 Gr.F6a
Cover bolt / nut	ASTM A193 Gr.B7/A194 Gr.2H
Arm	ASTM A105 (1 1/2" - 12") ASTM A216 Gr.WCB (14" & larger)
Gasket	See Page 7.
Plug	ASTM A576 Gr.1045

Dimensions

Valve Size	in	1 1/2	2	2 1/2	3	4	5	6	8	10	12	14	16	18	20	24	28	30
	mm	40	50	65	80	100	125	150	200	250	300	350	400	450	500	600	700	750
L ₁	in	9.50	10.50	11.50	12.50	14.00	15.75	17.50	21.00	24.50	28.00	33.00	34.00	38.50	40.00	53.00	59.00	62.75
	mm	241	267	292	318	356	400	444	533	622	711	838	864	978	1016	1346	1499	1594
L ₂	in	9.50	10.50	11.50	12.50	14.00	15.75	17.50	21.00	24.50	28.00	33.00	34.00	38.50	40.00	53.00	59.00	62.75
	mm	241	267	292	318	356	400	444	533	622	711	838	864	978	1016	1346	1499	1594
H	in	5.5	6.5	7.5	8.1	8.9	9.8	10.7	13.0	14.2	16.0	18.9	21.1	22.6	24.8	31.7	36.6	38.4
	mm	140	165	190	205	225	250	272	330	360	406	480	535	575	630	805	930	975

Class 600

Cast Carbon Steel Check Valve

Bolted cover, Swing type disc.



600 SCO

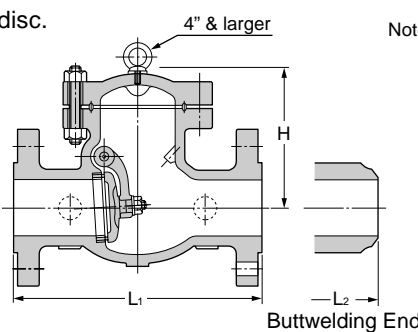

Note : Refer to Page 2 & 3 for standard seat material and construction.

Fig	End Connections
600 SCO	RF-flanged with smooth finish on gasket surface.
W600 SCO	Butt-welding ends.

Standard materials of parts

Parts	Materials
Body	ASTM A216 Gr.WCB
Cover	ASTM A216 Gr.WCB
Disc	ASTM A182 Gr.F6a (2" - 6") ASTM A216 Gr.WCB + 13Cr (8" & larger)
Disc nut	ASTM A194 Gr.8
Body seat ring	ASTM A182 Gr.F6a (2" - 14") ASTM A105+13Cr (16" & larger)
Cover bolt / nut	ASTM A193 Gr.B7/A194 Gr.2H
Arm	ASTM A105 (2" - 12") ASTM A216 Gr.WCB (14" & larger)
Gasket	See Page 7.
Plug	ASTM A576 Gr.1045

Dimensions

Valve Size	in	2	2 1/2	3	4	6	8	10	12	14	16	18	20	24
	mm	50	65	80	100	150	200	250	300	350	400	450	500	600
L ₁	in	11.50	13.00	14.00	17.00	22.00	26.00	31.00	33.00	35.00	39.00	43.00	47.00	55.00
	mm	292	330	356	432	559	660	787	838	889	991	1092	1194	1397
L ₂	in	11.50	13.00	14.00	17.00	22.00	26.00	31.00	33.00	35.00	39.00	43.00	47.00	55.00
	mm	292	330	356	432	559	660	787	838	889	991	1092	1194	1397
H	in	7.1	7.8	8.7	10.1	12.5	14.0	16.3	17.7	21.9	23.7	25.0	27.8	33.7
	mm	180	197	220	256	318	356	415	450	556	601	635	707	856