

## 2000 WOG - 2 PIECE FULL PORT STAINLESS STEEL BALL VALVE

**FIG. V2**

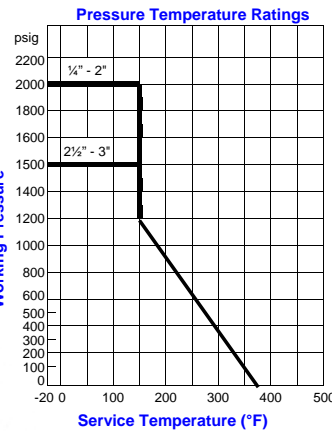
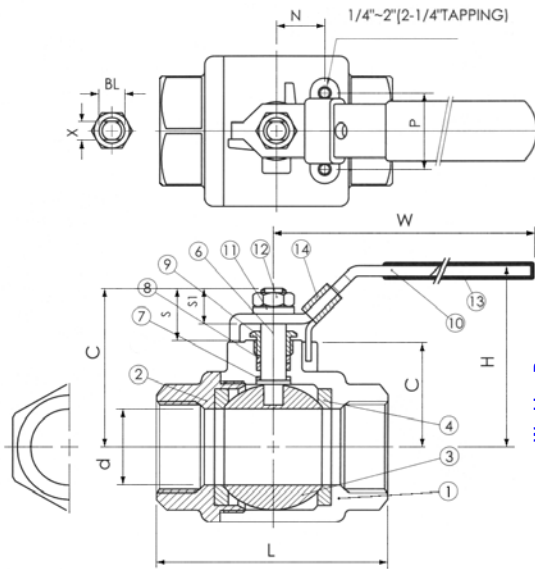

Valves - Threaded: ANSI B16.34  
 Ends: MSS SP-110, ASME B16.25, MSS SP-72  
 Marking: MSS SP-25  
 Testing: API 598  
 Threaded ends: ANSI B1.20.1  
 Size range: 1/4" to 3"  
 Pressure 1/4" to 2": 2000 psi (WOG)  
 Pressure 2 1/2" to 3": 1500 psi (WOG)

**Materials:**

No.	Part Name	Specification
1	Body	ASTM A351-CF8M
2	End Cap	ASTM A351-CF8M
3	Ball	ASTM A351-CF8M/316
4	Seat	15% R-PTFE
5	Joint Gasket	PTFE
6	Stem	ASTM A276-316
7	Thrust Washer	PTFE
8	Stem Packing	PTFE
9	Gland	ANSI 304
10	Handle	ANSI 304
11	Spring Washer	ANSI 304
12	Handle Nut	ANSI 304
13	Handle Cover	PVC
14	Lock Device	ANSI 304

**Options:**

- V: Vented ball
- M: Tapped Mounting pad
- P: equipped with Pneumatic actuator
- U: UNC or UNF threads for mounting pad
- L: Locking Device

**Dimensions:**

Size		i d		L		S	S1	BL	P	H		X	W		N	Weights	
in	mm	in	mm	in	mm	mm	mm	in	mm	in	mm	mm	in	mm	mm	lb	kg
1/4"	8	.46	11.6	2.38	60.5	16.5	10.2	5/16"	28.5	2.09	53	5	3.74	95	12.5	.73	0.33
3/8"	10	.5	12.7	2.38	60.5	16.5	10.2	5/16"	28.5	2.09	53	5	3.74	95	12.5	.73	0.33
1/2"	15	.59	15	2.46	62.5	16.5	10.2	5/16"	28.5	2.09	53	5	3.74	95	12.5	.75	0.34
3/4"	20	.79	20	3.03	77	20	13.5	3/8"	34.8	2.36	60	6.5	4.33	110	21	1.32	0.60
1"	25	.99	25.4	3.54	90	23.5	16	7/16"	34.8	2.91	74	8	5.31	135	22.5	2.24	1.02
1 1/4"	32	1.26	32	3.94	100	23.5	16	7/16"	38.1	3.15	80	8	5.31	135	23.5	3.45	1.57
1 1/2"	40	1.5	38	4.65	118	25.5	17	1/2"	38.1	3.62	92	9	6.5	165	23.5	5.02	2.28
2"	50	2	50.8	5.43	138	25.5	17	1/2"	38.1	3.98	101	9	6.5	165	34	8.14	3.7
2 1/2"	65	2.6	65	6.57	167	41	29.5	3/4"	56	5.12	130	12	8.46	215	35	15.62	7.1
3"	80	3.15	80	7.6	193	41	29.5	3/4"	56	5.59	142	12	8.46	215	35	25.7	11.68