

300# WOG STAINLESS STEEL PISTON CHECK VALVE

FIG. T3PC

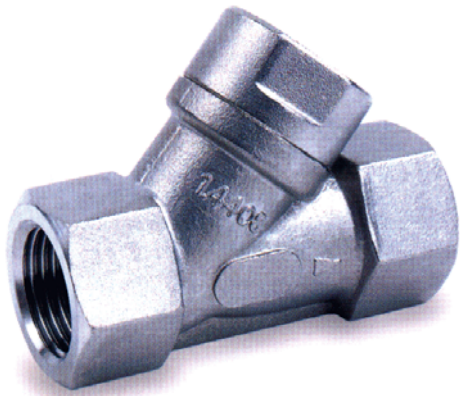

Marking: MSS SP-25
 Ends: MSS SP-110, ANSI B2.1
 Size range: ¼" to 2"
 Pressure ¼" to 2": 300 psi (WOG)
 Max. Temperature: 440 °F
 Investment Casting
 PN40 rating

Materials:

No.	Part Name	Specification
1	Body	ASTM A351-CF8M
2	Cap	ASTM A351-CF8M
3	Spring	AISI 316
4	Disc	AISI 316
5	Seat	PTFE
6	Washer	AISI 304
7	Nut	AISI 304
8	Joint Gasket	PTFE

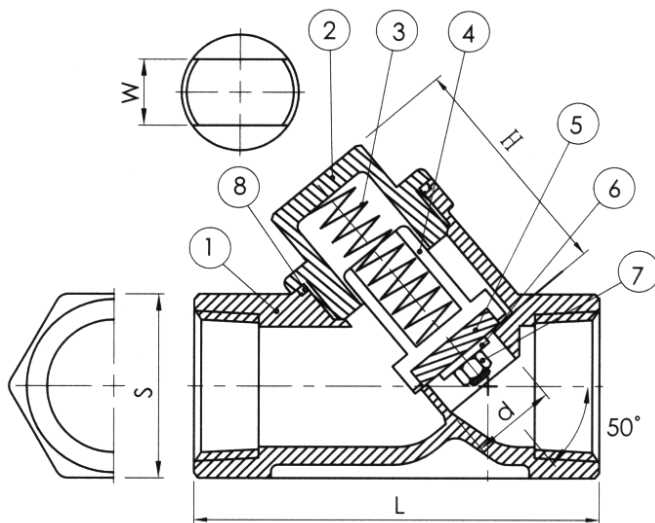

Dimensions:

Size		d		L		S		H		W	
in	mm	in	mm	in	mm	in	mm	in	mm	in	mm
¼"	8	.46	11.6	2.58	65.5	1.06	27	1.5	38	.94	24
⅜"	10	.49	12.5	2.58	65.5	1.06	27	1.5	38	.94	24
½"	15	.49	12.5	2.58	65.5	1.06	27	1.42	36	.94	24
¾"	20	.71	18	2.97	75.5	1.26	32	1.73	44	1.18	30
1"	25	.93	23.5	3.56	90.5	1.61	41	2.24	57	1.38	35
1¼"	32	1.24	31.4	4.37	111	1.97	50	2.52	64	1.57	40
1½"	40	1.41	35.7	4.76	121	2.19	55.5	2.99	76	1.77	45
2"	50	1.79	45.5	5.94	151	2.76	70	3.43	87	2.17	55