

**BRASS BALL VALVES**

**FIG: 320T- CU** 2 piece, Full Port Ball valve, 600# WOG, NPT ends, PTFE seats



150# SWP, 600# WOG  
Meets MSS SP-110 Specifications  
Meets CSA ½ psi, 5 psi & 125 psi Specifications

**Materials:**

No.	Part Name	Qty	Specification
1	Body	1	Brass 59 ASTM C37800
2	End Cap	1	Brass 59 ASTM C37800
3	Ball (Chrome Plated)	1	Brass 59 ASTM C37800
4	Seat Rings	2	PTFE
5	Stem	1	Brass 59 ASTM C37800
6	O-Rings	2	NBR
7	Friction Washer	1	PTFE
8	Handle	1	Steel ANSI 1015
9	Nut	1	Steel
10	Spring Washer	1	Steel

**Note:** Above 2" are not CSA/UL listed.

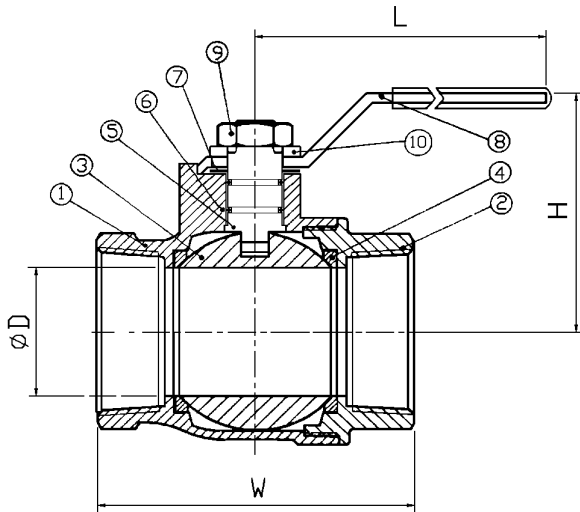

**Dimensions:**

Size	i D	W	H	L	Wt. lb
¼"	8	41.8	42	60	.2
⅜"	10	47.5	47	85	.34
½"	14	58.7	52	90	.48
¾"	19	67.6	52.4	90	.73
1"	24	79.6	58.6	115	1.21
1¼"	31	92.5	76	141	1.85
1½"	38	95	80	141	2.53
2"	49	114	90	151	3.74
2½"	64	140.2	122.5	211	6.86
3"	79	162	133	211	9.53
4"	99	189	156	260	17

**PRESSURE/TEMPERATURE RATING**

