

**BRASS BALL VALVES**

**FIG: 320C** 2 piece, Full Port Ball valve, 600# WOG, Solder ends, PTFE seats



600# WOG  
Meets MSS SP-110 Specifications

**Materials:**

No.	Part Name	Qty	Specification
1	Body	1	Brass 59 ASTM C37800
2	End Cap	1	Brass 59 ASTM C37800
3	Ball (Chrome Plated)	1	Brass 59 ASTM C37800
4	Seat Rings	2	PTFE
5	Stem	1	Brass 59 ASTM C37800
6	O-Rings	2	NBR
7	Friction Washer	1	PTFE
8	Handle	1	Steel
9	Nut	1	Steel ANSI 1010
10	Spring Washer	1	Steel

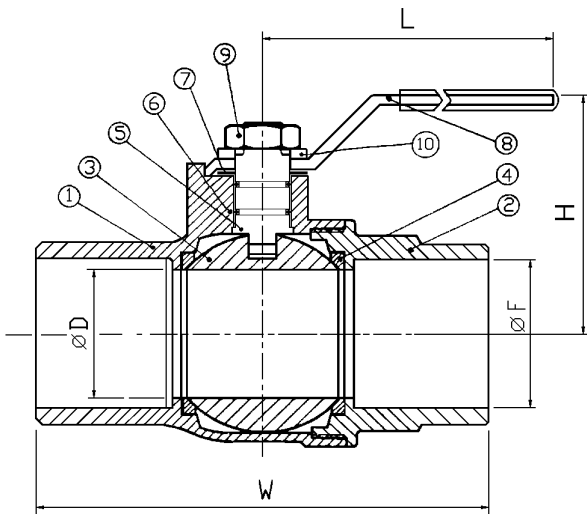

**Dimensions:**

Size	i D	i F	W	H	L	Wt. lb
½"	14	16	52.6	50	90	.42
¾"	19	22.3	74	54.5	95	.69
1"	24	28.7	90	62.7	115	1.08
1¼"	31	35	99	73.5	140	1.68
1½"	38	41.4	113.5	75	140	2.31
2"	49	54.1	133	86.5	150	3.45
2½"	64	66.8	159.2	122.5	210	7.7
3"	79	79.5	186	133	210	10.06
4"	99	104.9	235	156	260	17.56

**PRESSURE/TEMPERATURE RATING**

