

# Class 600 Gate Valve

Pressure-Temperature Rating: ASME B16.34

**AK 600UMM** Threaded Ends  
**AW600UMM** Socket Welding Ends

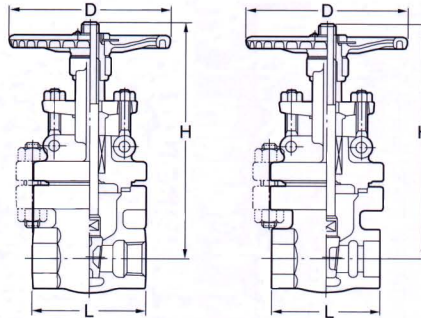

Parts	Material
Body	CF3M
Bonnet	CF8M
Stem	316
Disc	CF8M
Gland	316
Gland packing	Refer to Page 6
Gland flange	CF8
Handwheel	Ductile iron
Gasket	Refer to Page 6
Bonnet bolt/nut	B8/8
Gland bolt/nut	B8/8
Yoke sleeve	Ductile Ni-resist
Name plate	Aluminum

Note : Flexible wedge for all sizes.

		AK600UMM					AW600UMM				
Size	in.	1/2	3/4	1	1 1/2	2	1/2	3/4	1	1 1/2	2
	mm	15	20	25	40	50	15	20	25	40	50
L	in.	3.0	3.25	3.75	5.0	5.75	2.87	3.15	3.62	4.88	5.63
	mm	76	83	95	127	146	73	80	92	124	143
H (open)	in.	7.9	8.46	9.5	12.8	15.2	7.9	8.46	9.5	12.8	15.2
	mm	201	215	240	325	385	201	215	240	325	385
D	in.	3.9	3.9	5.5	7.1	7.9	3.9	3.9	5.5	7.1	7.9
	mm	100	100	140	180	200	100	100	140	180	200

End-to-End Dimensions: KITZ Std.  
 Connecting Threads: ASME B1.20.1  
 Connecting Sockets: ASME B16.11  
 Wall Thickness: ASME B16.34