

**ANSI CLASS 150 STAINLESS STEEL GATE VALVE**

**FIG. 150GA**

Class 150, Flanged ends, Bolted bonnet, 316 Stainless steel body & trim.



Flange dimensions: ANSI B16.5  
 Face-to-Face dimensions: ANSI B16.10  
 Wall thickness: ANSI B16.34/API 603  
 Testing: API 598

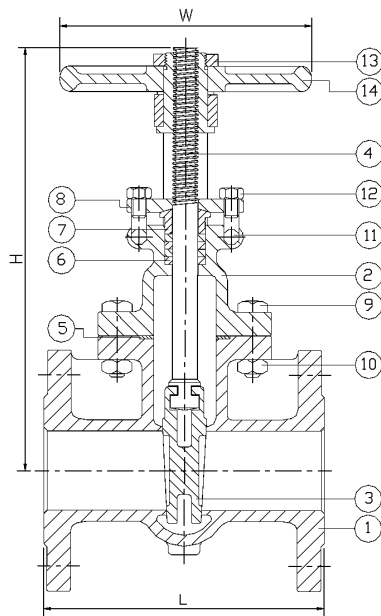

**Materials:**

No.	Part Name	Specification
1	Body	ASTM A351-CF8M
2	Bonnet	ASTM A351-CF8M
3	Disc	ASTM A351-CF8M
4	Stem	ASTM A276-316
5	Gasket	15% RPTFE
6	Packing	15% RPTFE
7	Packing Gland	AISI 316
8	Gland Flange	ASTM A351-CF8M
9	Bonnet Bolts	ASTM A193-B8
10	Bonnet Nuts	ASTM A194-8
11	Gland Studs	ASTM A193-B8
12	Gland Nuts	ASTM A193-8
13	Wheel Nut	AISI 304
14	Handwheel	ASTM A536

**Dimensions:**

Size		L		H (Open)		W		Weight	
in	mm	in	mm	in	mm	in	mm	lb	kg
½"	15	4.25	108	7.2	183	4.72	120	6.6	3
¾"	20	4.61	117	7.48	190	4.72	120	7.7	3.5
1"	25	5	127	8.27	210	4.72	120	11	5
1½"	40	6.5	165	10.63	270	7.87	200	17.6	8
2"	50	7	178	12.6	320	7.87	200	24.2	11
2½"	65	7.5	191	14.76	375	7.87	200	33	15
3"	80	8	203	17.52	445	9.84	250	48.4	22
4"	100	9	229	20.59	523	9.84	250	70.4	32
6"	150	10.5	267	27.95	710	11.81	300	143	65
8"	200	11.5	292	35.83	910	13.78	350	222	101
10"	250	13	330	43.98	1117	15.75	400	312	142
12"	300	14	356	52.13	1324	15.75	400	460	209
14"	350	15	381	59.8	1519	19.69	500	818	372